

Floor Heating System

THERMAT

INSTALLATION GUIDE

October 2009 Edition

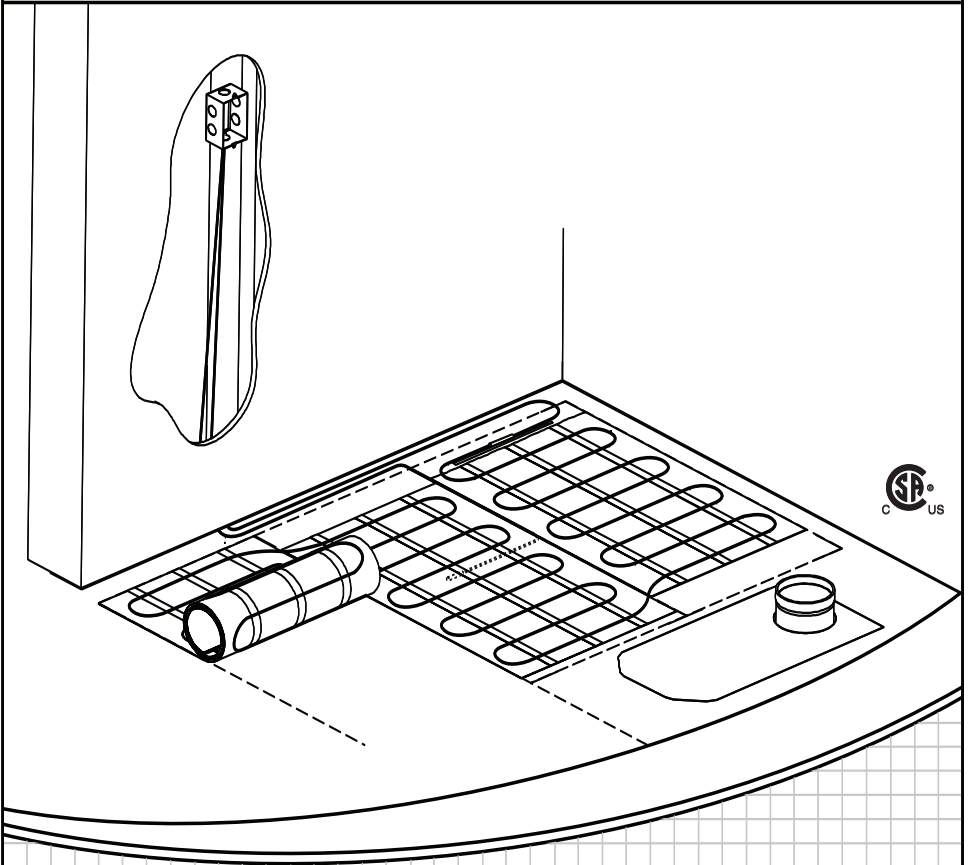

OUELLET
ELECTRIC HEATING

www.ouellet.com

1	Thermat Floor Heating System	4
1.1	General Information (Components, figure 1.1)	4 5
1.2	Always	6
1.3	Never	7
2	Technical Information	8
2.1	Surface Area and Power Output of Thermat Products	8
2.2	Insulation Test	10
2.3	Resistance Test	11
3	Types of Heating and Floor Coverings	12
3.1	Floor Warming	12
3.2	Radiant Floor Heating	12
3.3	Typical Floor Coverings	13
4	Installation Instructions	14
4.1	Planning Work	14
4.2	Preparing the Subfloor	15
4.3	Marking the Floor	15
4.4	Installing the Thermat Floor Heating System	17
4.4.1	Working Around Walls and Obstacles	18
4.4.2	Mat Rippling	19
4.5	Installing the Temperature Sensor	20
4.6	Applying Self-Levelling Cement	21
4.7	Connecting the System	22
4.8	Measuring Resistance and Measures' Table	22
4.9	Using the Thermat System	23
5	Temperature Regulation	23
6	FAQ	24
6.1	Floor Heating System	24
6.2	Installation	24
7	Expert Tips: Installation and Floor Covering	26
7.1	Installation Tips	26
7.2	Floor Covering Tips	26
8	Warranty	27
8.1	Warranty Statement	27

1.1 General Information



IMPORTANT

The installation must meet the following building codes, as applicable:

- Canadian Electrical Code (CSA C22.1)
 - American National Electricity Code (ANSI/NFPA 70)
 - Any other national or local code
-

The **Thermat** floor heating system is composed of a heating cable fastened to an adhesive fiberglass mat along with a lead for connection to an electrical power source. **Thermat** meets the following The Canadian Electrical Code standard: series heating cables set.



IMPORTANT

Shut off power supply to the floor heating system to prevent electrical shock.

Important Informations

- The **Thermat** floor heating system is designed exclusively for interior floor heating. The system is not designed for snow melting or any other outdoor uses;
- **Thermat** is mainly designed to complement a building's primary heating source by serving as a secondary (floor warming) or primary room heat source (radiant floor heating);
- Refer to Section 3 for instructions on heating a room using the **Thermat** system only;
- Floor temperature varies based on insulation and floor characteristics;
- The **Thermat** system can be installed under a shower floor only if the floor is ceramic or natural stone. A waterproof membrane must be used to maintain the heating cables in a dry environment. **Canada:** A ground fault circuit interrupter (GFCI) must be used with this heating device in bathrooms. **USA:** A ground fault circuit interrupter (GFCI) must be used with this heating device in bathrooms and in hydromassage bathtub locations;
- The **Thermat** system must be embedded in cement or an equivalent binder (cement glue, ceramic glue or self-levelling cement);
- The system must be installed by a master electrician who is: able to evaluate proper electrical resistance, familiar with installation-related risks and knowledgeable about construction techniques as well as the installation and use of the **Thermat** floor heating system;
- The system is only one step in the floor construction process. Each trade is responsible for the quality of its work and must ensure that the work performed by the previous tradesman has been duly completed according to code. All tradesmen are engaged in the installation process and share joint responsibility for it.

Components

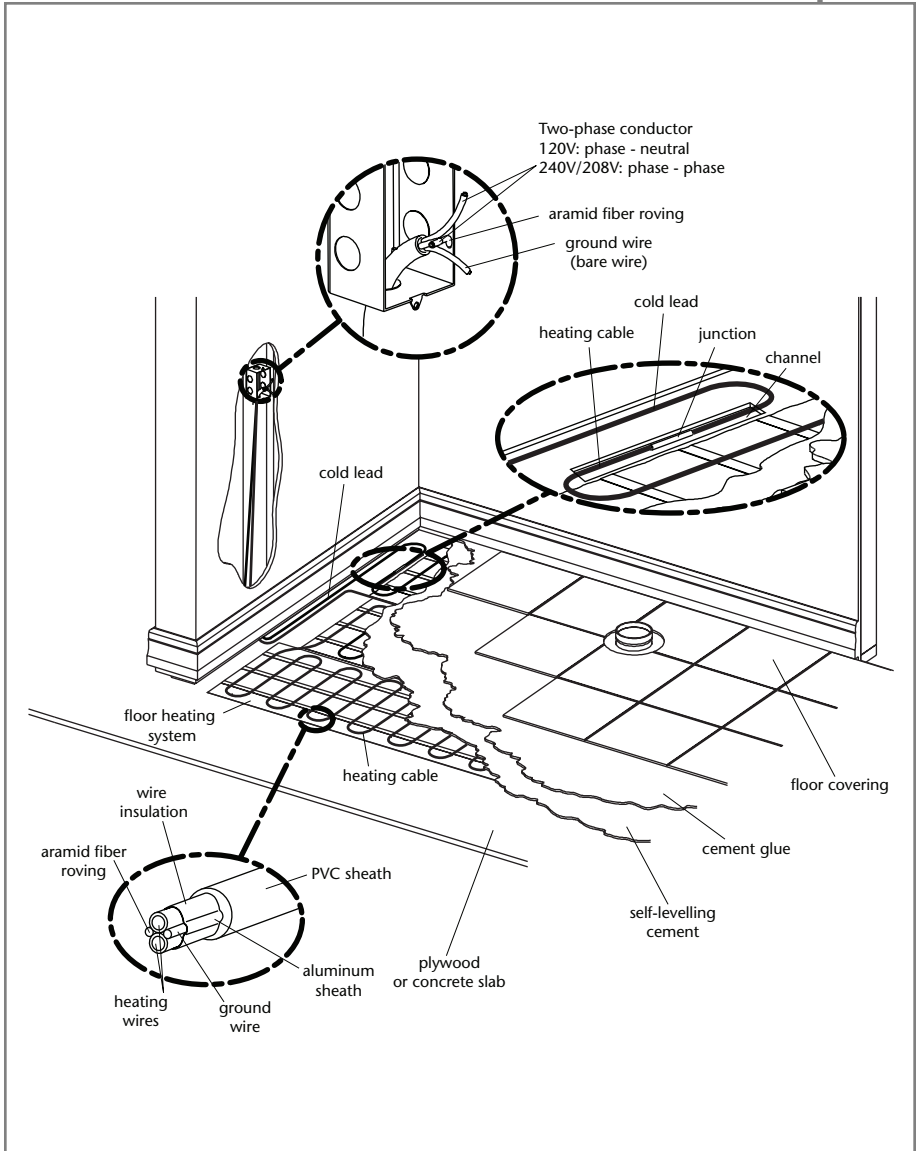

Fig. 1.1

1.2 Always

- Read this guide in full before installing the product;
- Install the **Thermat** system with a regulating device;
- Use copper wires only;
- Perform the mandatory tests described in this guide and record readings on the table of measures;
- Only use cement or an equivalent binder compatible with floor heating systems (cement glue, ceramic glue, self-levelling cement);
- Ensure that the black heating cable is completely embedded in cement or an equivalent binder (cement glue, ceramic glue, self-levelling cement);
- Ensure that the voltage supplied equals the nominal voltage of the **Thermat** system;
- Repair the product only using the **Thermat** repair kit available at your authorized Ouellet Canada Inc. dealer;
- Consult Ouellet Canada Inc.'s team of technical specialists for any questions or for more information;
- Install **Thermat** at temperatures over 5 °C (40 °F);
- Heating cables must be at least 13 mm (1/2") away from any combustible surface.
- Metal structures or materials used for the support of or on which cables or sets are installed be grounded in accordance with the Canadian Electrical Code (CSA C22.1 Section 10 and National Electrical Code);
- The installer of series heating cable sets must inspect and remove damaged or defective heating cable sets before they are covered or concealed;
- The installer of series heating cable sets must mark the appropriate circuit breaker reference (label) indicating which circuit supplies the circuit to those electric heating cables.

1.3 Never

- Install **Thermat** sections so that the heating cables are less than 76 mm (3") from each other. The temperature could be too high and could causes damages;
- Shorten or alter any part of the heating cable (fig. 1.3);
- Cross, overlap, or stack heating cables (they must not touch);
- Connect a 120V product to a 240V/208V power source;
- Use a bending radius under 20 mm (3/4");
- Install a temperature regulator (thermostat or other) where it is accessible from the shower or bath (install at least 1 m [3' 4"] away);
- Staple heating cable or floor sensor end to the subfloor (fig. 1.3);
- Install the **Thermat** system if the safety seal is broken;
- Install the **Thermat** system under a closet or fixed items;
- Series heating cable sets shall not extend from beyond the room or area in which they originate;
- Series heating cable sets are not to be installed in walls.

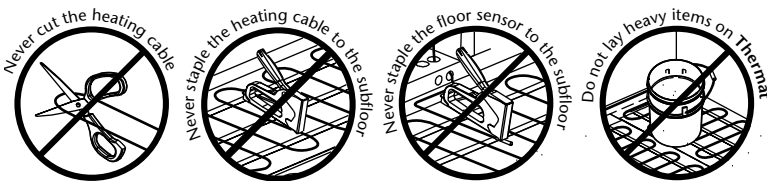

Fig. 1.3

2.1 Surface Area and Power Output of Thermat Products

Product # 120V	Width		Length		Surface area		Power	Resistance
	in.	m	ft.	m	sq. ft.	sq. m	Watts	ohm
OTM0082	16	0.41	6'	1.8	8	0.7	85	169.4
OTM0122	16	0.41	7' 6"	2.3	10	0.9	120	120.0
OTM0152	16	0.41	10'	3.0	13	1.2	150	96.0
OTM0172	16	0.41	11' 6"	3.5	15	1.4	170	84.6
OTM0242	16	0.41	15'	4.6	20	1.9	240	59.9
OTM0302	16	0.41	19'	5.8	25	2.4	300	47.5
OTM0362	16	0.41	22' 6"	6.9	30	2.8	360	39.6
OTM0422	16	0.41	26' 6"	8.1	35	3.3	420	33.7
OTM0472	16	0.41	30'	9.1	40	3.7	475	29.8
OTM0602	16	0.41	37' 6"	11.4	50	4.6	600	23.3
OTM0722	16	0.41	45'	13.7	60	5.6	720	19.0
OTM0842	16	0.41	52' 6"	16.0	70	6.5	840	16.2
OTM0962	16	0.41	60'	18.3	80	7.4	960	14.2
OTM0842-32	32	0.82	26' 3"	8.0	70	6.5	840	16.2
OTM0962-32	32	0.82	30'	9.1	80	7.4	960	14.2

Product # 240V/208V	Width		Length		Surface area		Power	Resistance
	in.	m	ft.	m	sq. ft.	sq. m	Watts	ohm
OTM0170	16	0.41	11' 6"	3.5	15	1.4	170	338.8
OTM0240	16	0.41	15'	4.6	20	1.9	240	240.0
OTM0300	16	0.41	19'	5.8	25	2.4	300	192.0
OTM0360	16	0.41	22' 6"	6.9	30	2.8	360	159.8
OTM0420	16	0.41	26' 6"	8.1	35	3.3	420	137.0
OTM0475	16	0.41	30'	9.1	40	3.7	475	121.1
OTM0600	16	0.41	37' 6"	11.4	50	4.6	600	95.0
OTM0720	16	0.41	45'	13.7	60	5.6	720	79.2
OTM0840	16	0.41	52' 6"	16.0	70	6.5	840	67.4
OTM0960	16	0.41	60'	18.3	80	7.4	960	59.0
OTM1080	16	0.41	67' 6"	20.6	90	8.4	1080	51.8
OTM1200	16	0.41	75'	22.9	100	9.3	1200	46.6
OTM1440	16	0.41	90'	27.4	120	11.1	1440	37.9
OTM1600	16	0.41	105'	32.0	140	13.0	1600	34.1
OTM1920	16	0.41	120'	36.6	160	14.9	1920	28.4
OTM0840-32	32	0.82	26' 3"	8.0	70	6.5	840	67.4
OTM0960-32	32	0.82	30'	9.1	80	7.4	960	59.0
OTM1080-32	32	0.82	33' 9"	10.3	90	8.4	1080	51.8
OTM1200-32	32	0.82	37' 6"	11.4	100	9.3	1200	46.6
OTM1440-32	32	0.82	45'	13.7	120	11.1	1440	37.9
OTM1600-32	32	0.82	52' 6"	16.0	140	13.0	1600	34.1
OTM1920-32	32	0.82	60'	18.29	160	14.9	1920	28.4

208V = 75% of wattage at 240V.

2.2 Insulation Test



Measure **Thermat's** insulation resistance at each step using a megohmmeter (fig. 2.2) and record readings on the measures' table (this label is available at the opening of the product).



IMPORTANT

For the warranty to be valid, fill out the measures' table and ensure that the 10 readings have been correctly noted.

A qualified electrician must measure the system's insulation resistance as follows:

- Use a calibrated megohmmeter only;
- Measure insulation resistance at the free end of the cold lead, between the phase conductor and ground;

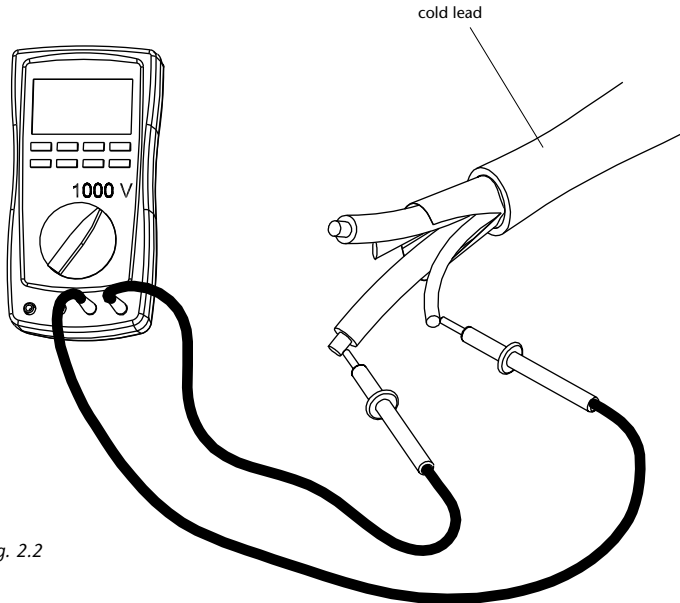

Fig. 2.2



CAUTION: Dangerous Test

- Write the reading in the measures' table;
- This reading must be over 1,000,000 ohms;
- If the reading is under 1,000,000 ohms, stop work and contact Ouellet Canada Inc.'s technical specialists at 1 800 463-7043.

2.3 Resistance Test



Measure the resistance of the **Thermat** heating cable at each step using a multimeter (fig. 2.3) and record readings on the measures' table.



IMPORTANT

For the warranty to be valid, fill out the measures' table and ensure that the 10 readings have been correctly noted.

A qualified electrician must measure the system's resistance as follows:

- Use a calibrated multimeter only;
- Measure resistance at the free end of the cold lead, between the two phase conductors;

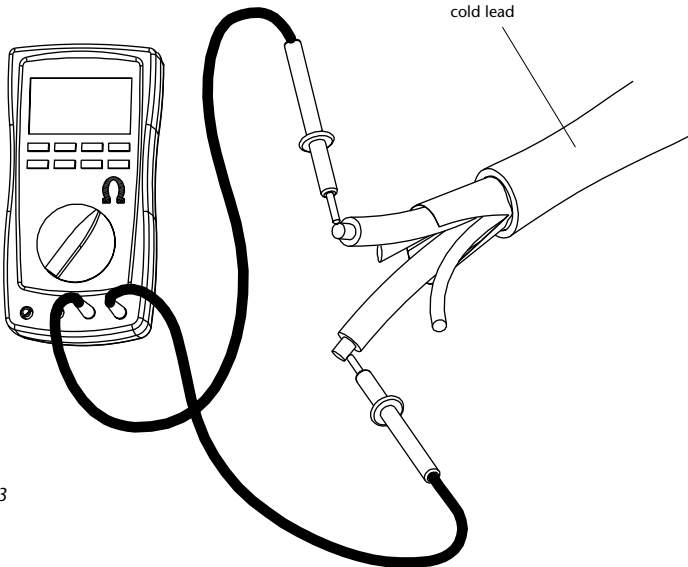

Fig. 2.3

- Write the reading in the measures' table;
- Verify the heating cable integrity by comparing your reading to the value on the cold lead label;
- If your reading is off (see Table 2.1) at any step, stop work and contact Ouellet Canada Inc.'s technical specialists at 1 800 463-7043.

The **Thermat** floor heating system can be used for two purposes maximizing comfort.

Used as a secondary heat source (floor warming), it can help keep floor temperature comfortable year round. Used as a primary room heat source (radiant floor heating), it provides uniform, comfortable, and enveloping warmth. For the latter use, it is important to follow the specific recommendations outlined below.

In light of environmental factors beyond Ouellet Canada Inc.'s control—including thermal insulation, heated area, floor covering emissivity, heat loss, and more—we cannot guarantee that the **Thermat** system will provide a completely uniform surface temperature in all cases, no matter how careful the installation. Consequently, Ouellet Canada Inc. cannot be held liable for any discomfort (e.g., a cold area on the floor) caused by site-specific deficiencies. Ouellet Canada Inc.'s liability is limited to the performance of its products.

3.1 Floor warming

This type of heating is designed to enhance comfort and/or supplement the room's main heat source. It helps keep the floor at a pleasant temperature at all times.

Installing this type of system is very easy: simply unroll the adhesive **Thermat** floor heating system directly on the floor, embed the heating cable in cement or an equivalent binder (cement glue, ceramic glue, self-levelling cement) and install the floor covering. Use the floor coverings listed in Section 3.3 and connect the **Thermat** system to an appropriate thermostat, described in Section 5.

3.2 Radiant Floor Heating

Thermat can be used as the room's primary heat source. It can heat a room using the **Thermat** system only. Proceed as follows:

- Connect the system to an ambient temperature regulator;
- Calculate heat loss to ensure the system has enough power to heat the room;
- Sufficient insulation under the subfloor is very important. This insulation is to be sure that the heat will rise into the room to be heated;
- Make sure to have a floor covering that meets the specifications listed in table 3.3.



IMPORTANT

Do not install a radiant floor heating system on a noninsulated or poorly insulated subfloor, or over a crawl space.

The efficiency of this type of primary room heating system will depend on factors such as surface area, heat conductivity of the floor covering, insulation on outside walls, etc. We recommend that you verify these points and seek professional advice before investing time and money.

3.3 Typical Floor Coverings



IMPORTANT

The thermal resistance of the floor covering must not exceed $R = 1.40$ ($RSI = 0.246$). There is no such limit for the subfloor.

Typical floor covering	Thermal resistance	
	R	RSI
Vinyl tiles	0.20	0.035
Linoleum	0.22	0.039
Ceramic	0.25	0.044
Low-pile carpet	0.70	0.123
Parquet flooring	0.70	0.123
Floating floor 10 mm to 16 mm (3/8" to 5/8")	0.70	0.123
Wood on lathes (strapping)*	2.10	0.368

Table 3.3 Thermal resistance values for floor coverings

* The floor covering highlighted in grey is prohibited.



IMPORTANT

For engineered wood floorings, laminated hardwood flooring, vinyl coverings, and linoleum glued to a concrete surface, consult your floor covering manufacturer to ensure they are compatible with floor heating systems.

4.1 Planning Work

Materials provided by Ouellet Canada Inc.

- Thermat floor heating system roll
- Installation instructions
- Electrical panel label
- Floor temperature sensor

Material required

- Temperature control with GFCI (available at Ouellet Canada Inc.)
- Cable check tester (available at Ouellet Canada Inc.)
- Stapler
- Protective glasses
- Measuring tape
- Broom
- Mop and bucket
- Felt marker
- Tape
- Hot glue gun
- Wood chisel
- Hammer
- Multimeter and megohmmeter
- Electrician tools
- Electrical tape

For installation over a concrete slab, add the following:

- Spray adhesive
- Concrete chisel

Room Layout and Corresponding Thermat Product

- Create a room layout plan to scale (for maximum accuracy, use the Ouellet Canada Inc form designed for this purpose);
- Identify all stationary elements (toilet, bath, shower, counters, drawers, and permanent furnishings) and never install the heating cable under these stationary elements (fig. 4.1);
- Determine thermostat or temperature control location;
- Note room dimensions;
- Determine cold lead location;
- Calculate the heating area in square feet (sq. ft.);
- Select the **Thermat** product from Table 2.1 to cover 80 % of the surface or subtract a minimum of 50 mm (2 in) around walls and stationary elements.

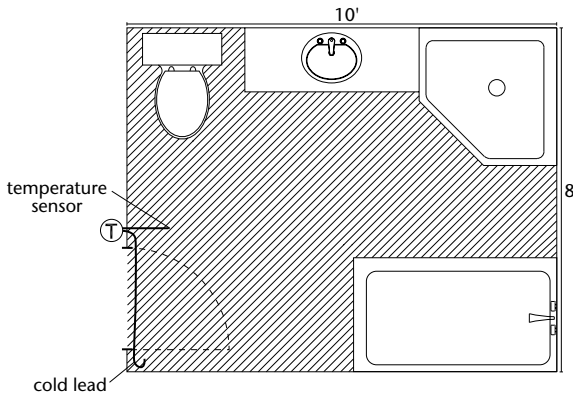

Fig. 4.1



We can help optimize your work plan. Fax it to us at 1 800 662-7801. Clearly indicate all dimensions. A minimum of one horizontal and one vertical dimensions are necessary to validate the scale.

4.2 Preparing the Subfloor

- Clean and remove any debris, dust, or protruding objects that could damage the heating cable. The surface must be clean and dry for the adhesive mat to adhere perfectly to the subfloor;
- Subfloor cracks must be filled with polyester wood filler;
- The subfloor must be solidly fastened in place to prevent movement;
- The application of a floor levelling product is recommended to prevent future damage to the ceramic caused by subfloor movement;
- For concrete subfloor, apply a surface sealer that is compatible with electrical heating systems in accordance with the cement glue manufacturer's instructions. Completely coat the surface;
- Let dry before installing the **Thermat** system (refer to the sealer's instructions for drying time).

4.3 Marking the Floor



Felt marker

- On the floor of an empty room (under construction or major renovations), draw the location of stationary elements (toilet, bath, shower, counters, drawers, permanent furnishings) that will be installed later. These marks will outline the heating area to ensure the **Thermat** system is not placed under these stationary elements (fig. 4.3 a);
- Draw lines on the floor the width of the mat 0.41 m (16") or 0.82 m (32");
- Indicate in which direction the **Thermat** system will be unrolled;

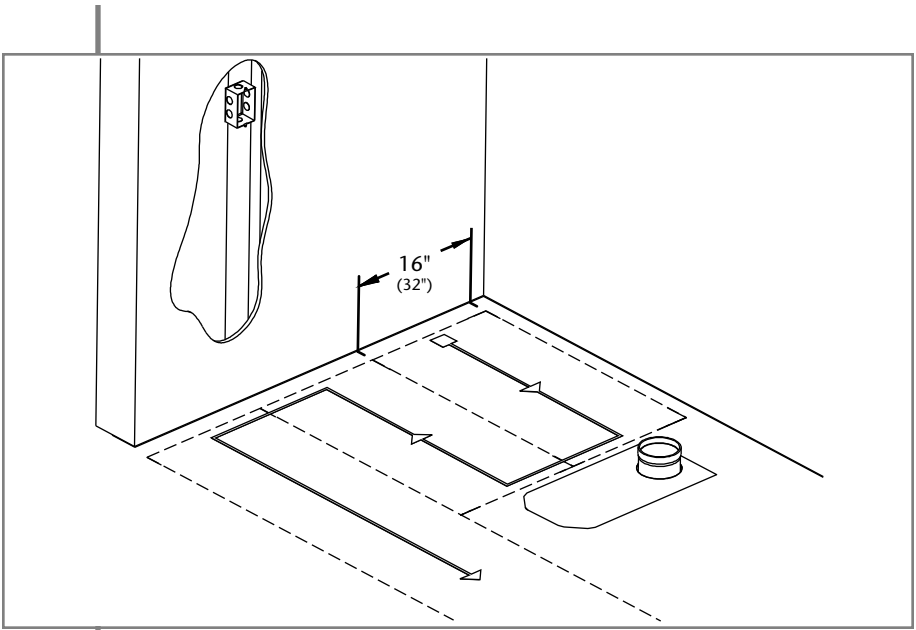

Fig. 4.3 a

- The floor temperature sensor must be centered between two parallel heating cables under the **Thermat** fiberglass mat (fig. 4.3 b). The ideal location is one where it is likely to be away from stationary objects and sheltered from outside influences (sunlight) that could skew floor temperature readings. For maximum comfort, the area above the sensor must be free of obstruction.

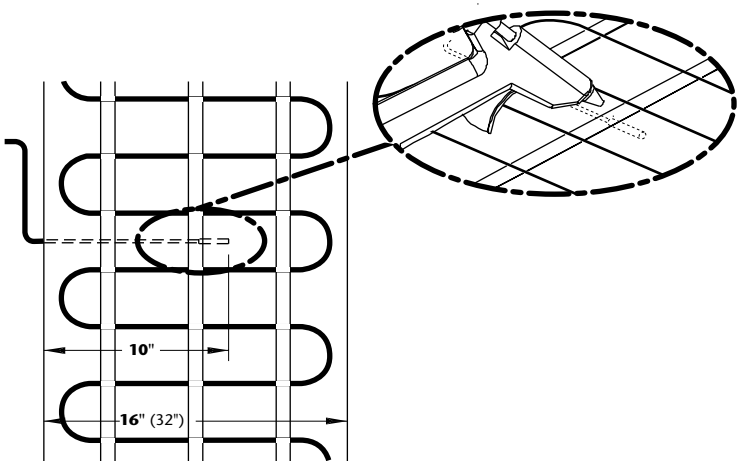
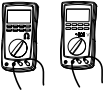

Fig. 4.3 b

4.4 Installing the Thermat Floor Heating System



Tape, spray adhesive, stapler



Remove the product from the box and verify the electrical and insulation resistance of the heating cable.

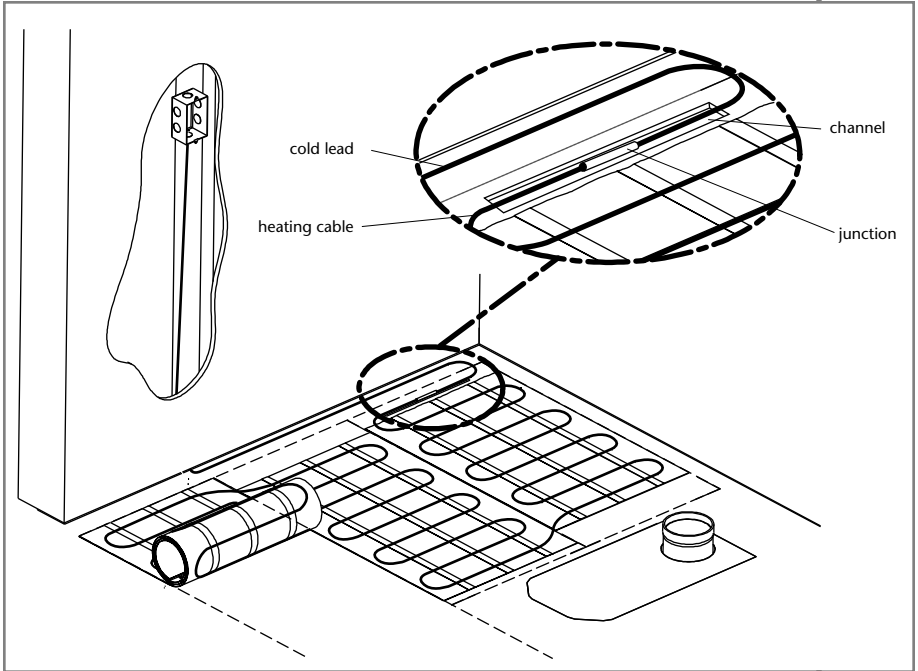

Fig. 4.4 a

- Unroll the mat, adhesive side down (fig. 4.4 a);
- Ensure that the cold lead is long enough to be connected to the thermostat or junction box;
- To minimize floor height, chisel a 10 mm x 10 mm x 250 mm (3/8" x 3/8" x 10") channel in the subfloor to receive the cold lead/heating cable (black) junction. The junction has an extra insulation sheath and a slightly larger diameter than the heating cable;
- Continue to unroll the **Thermat** system on the floor, working around the stationary elements marked out beforehand (see Section 4.4.1);
- As needed, reposition **Thermat**: its adhesive allows it to be positioned more than once.
- You may use hot glue or tape to fasten the **Thermat** to the subfloor;

- Staple the mat to the plywood subfloor to prevent the mat ends from curling;
- Use spray adhesive to fasten the **Thermat** to a concrete subfloor.

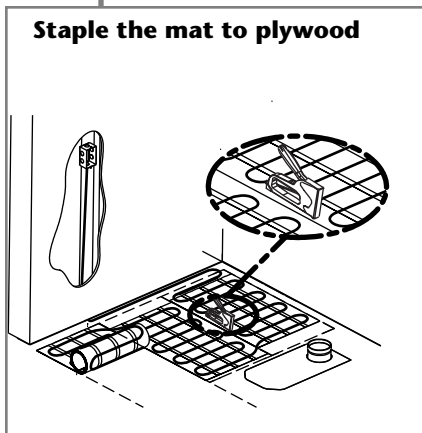

Fig. 4.4 b

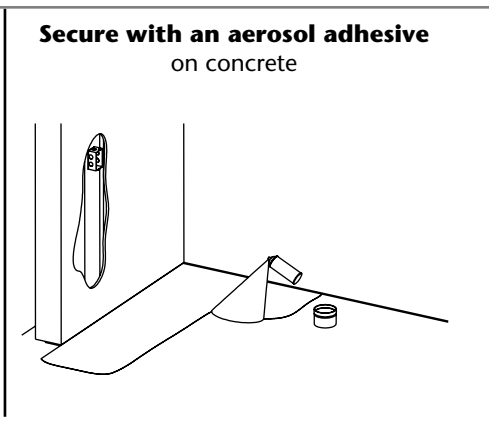

Fig. 4.4 c



IMPORTANT

Never staple the heating cable directly to the subfloor.



4.4.1 Working Around Walls and Obstacles

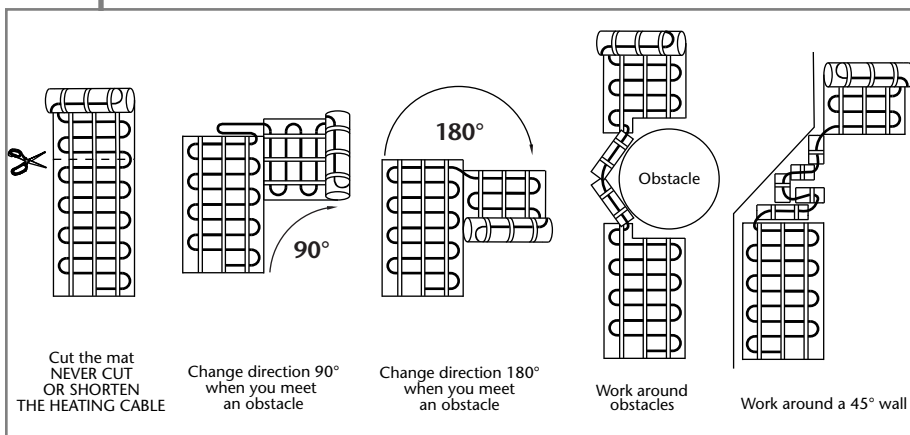

Fig. 4.4.1

- When the **Thermat** roll meets a wall or obstacle, simply cut the mat and pivot it in another direction (fig. 4.4.1);



IMPORTANT



Never cut or try to shorten the heating cable.

- Ensure that the **Thermat** surface is flat against the subfloor;
- Avoid walking on the **Thermat** system. If you must, wear soft rubber soled shoes;
- **Always start unrolling Thermat at least 50 mm (2") from the walls;**
- To work around stationary elements, detach a section of heating cable from the mat and use it to cover a tight space or work around an object;
- It is important not to subject the heating cable to any mechanical strain (stretching, radius bending under 20 mm [3/4"], scoring).

4.4.2 Mat Rippling

- Carefully flatten the mat against the subfloor to ensure it and the heating cable can be completely embedded in the cement or other binder to be applied in the next step;
- If the mat ripples, score the center of the rippled section and flatten the edges (fig. 4.4.2).

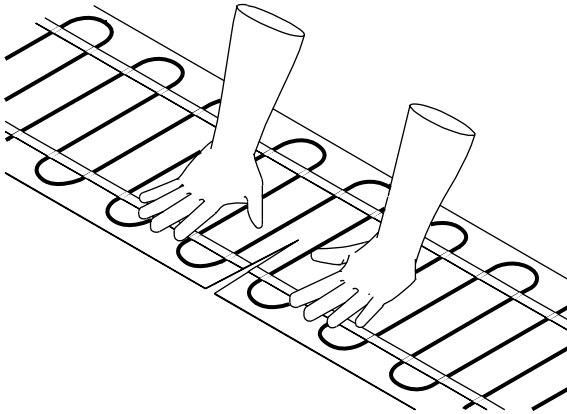

Fig. 4.4.2



IMPORTANT



Never cut or score the heating cable.



Measure the cable's electrical and insulation resistance and record the readings on line 2) *After installing the heating cable* of the measures' table.

4.5 Installing the Temperature Sensor



Hot glue gun, hammer, wood chisel or concrete chisel

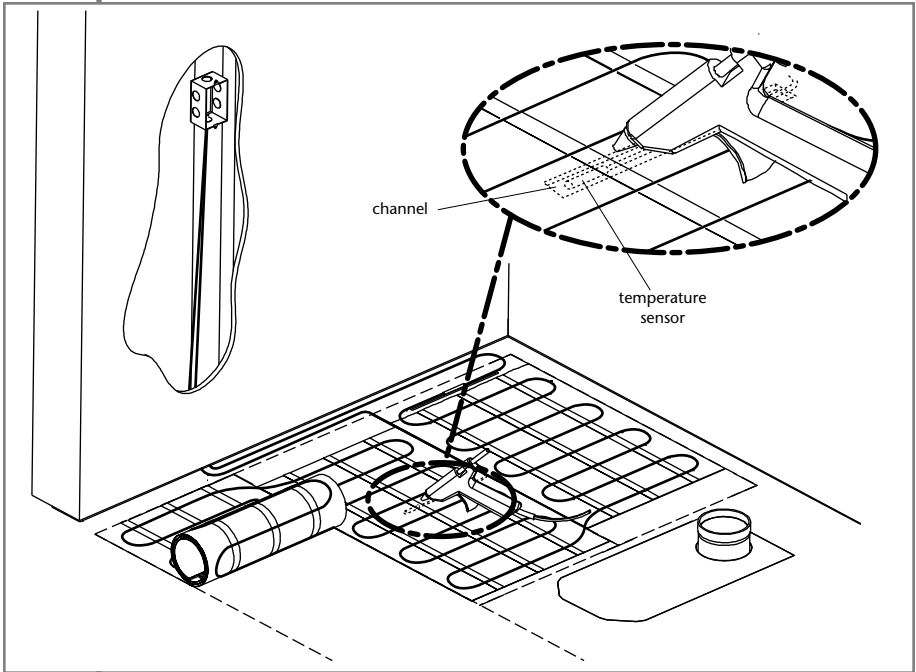

Fig. 4.5

- To minimize floor height, chisel a 10 mm x 10 mm x 250 mm (3/8" x 3/8" x 10") channel in the subfloor to receive the temperature sensor.



CAUTION!

The sensor must be embedded in cement or an equivalent binder (cement glue, ceramic glue, self-levelling cement).

- Glue the sensor to the subfloor (fig. 4.5). The sensor must be solidly fastened to the subfloor to ensure it stays in place when the cement or an equivalent binder (cement glue, ceramic glue, self-levelling cement) is applied.

4.6 Applying Self-Levelling Cement

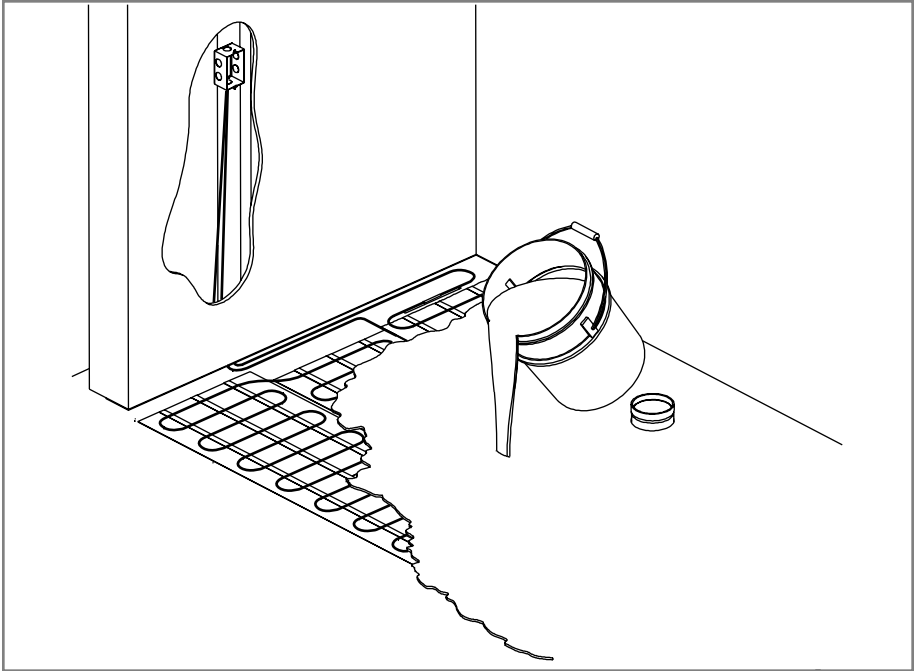
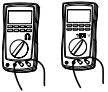

Fig. 4.6



Measure the cable's electrical and insulation resistance and record the readings on line 3) *Before embedding the heating cable in self-levelling cement* of the measures' table.

- Consult the manufacturer's instruction for the type of floor covering (ceramic, linoleum, or other). See Section 7, Expert Tips;
- Completely embed the heating cable in self-levelling cement (fig. 4.6). It is crucial that the ENTIRE cable be embedded. No part of the cable must be exposed;
- Level the subfloor with self-levelling cement or cover the cable with a layer of cement glue when installing the stones or ceramics.



IMPORTANT

Do not turn on the Thermat floor heating system before the cement has completely dried. Follow the manufacturer recommendations (may take up to 30 days, depending on the product).



Once the cement or binder has dried, measure the cable's electrical resistance and record readings on line 4) *After embedding the heating cable in cement* of the measures' table.

Final view

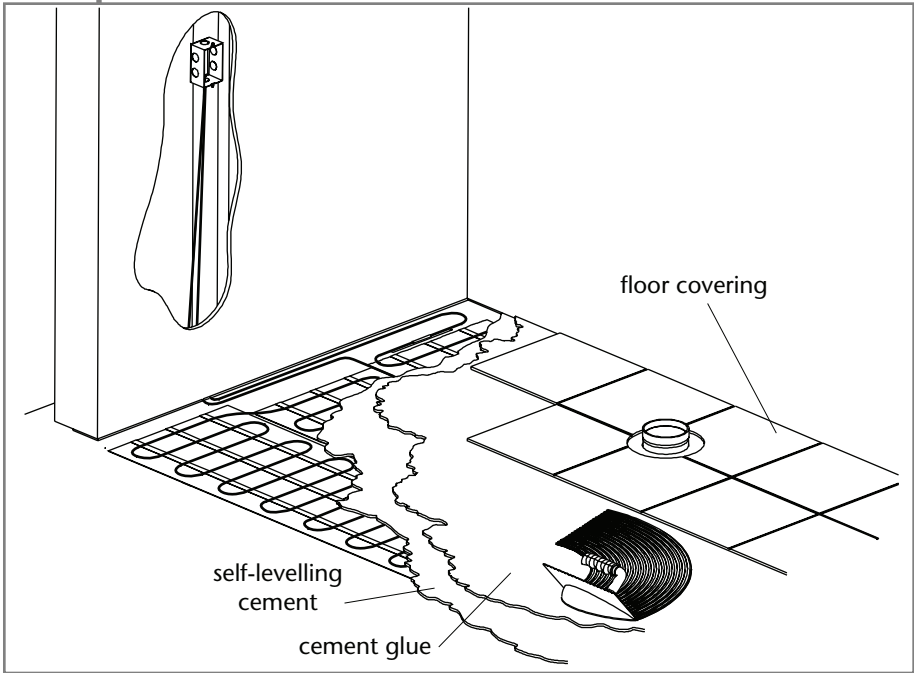

4.7 Connecting the System



IMPORTANT

The system must be connected by a master electrician.

Cold lead:

- | | |
|-------------------------|--------------------|
| - 240V/208V connection: | - 120V connection: |
| Line 1 - Black | Line - Black |
| Line 2 - Red | Neutral - White |
| Bare wire - ground | Bare wire - ground |



Measure the cable's electrical resistance and record the readings on line 5) Upon installing the thermostat of the measures' table.

4.8 Measuring Resistance and Measures' Table

- The master electrician who installed and connected the **Themat** system must complete the measures' table (this label is available at the opening of the product) and give it to the customer. This sheet must be kept near the electrical service.



IMPORTANT

If this table is not duly completed, the warranty may be annulled. Warranty terms are set out in Section 8.

4.9 Using the Thermat System

- The **Thermat** floor heating system is now ready for use. However, before turning on the system, make sure the curing period specified by the cement or binder manufacturer has expired. Adjust the thermostat's temperature based on your needs and desired level of comfort.

5. IMPORTANT!

The **Thermat** system must be controlled by a temperature control system.

If **Thermat** is to be used for floor warming, an electronic floor temperature control featuring a floor sensor is recommended to ensure heat levels never exceed the floor covering's maximum temperature tolerance.

If the system is to be used for radiant heating, the room thermostat controls heat and is reacting to room and not floor temperature therefore a floor covering with greater temperature resistance must be used.

The room temperature control and floor temperature sensor must never be installed where they will be exposed to sunlight or air drafts.



CAUTION!

The **Thermat** floor heating system must be connected to a ground fault circuit interrupter (GFCI) when installed in a bathroom. Ouellet Canada Inc. strongly recommends the use of a GFCI in all rooms featuring the **Thermat** system.

Recommended temperature regulation devices:

- 1- Thermostat with floor sensor and integrated GFCI (floor warming only).
 - 2- Rheostat dimmer switch with a GFCI.
 - 3- Electronic ambient thermostat with a GFCI (radiant room heating).
-

6.1 Floor Heating System

Q.1 : Can I cut the Thermat heating cable to shorten it?

A.1 : NEVER. If the Thermat roll is too long, detach the excess cable from the mat and spread it on the floor in regular loops identical to those on the mat. Keep the minimum distance from the walls and between parallel runs of cable (radius bending of at least 20 mm [3/4"] for loops).

Q.2 : What should I do before choosing the Thermat system that's right for me?

A.2 : Sketch a plan to determine the surface area. We can help optimize your work plan. Fax it to us at 1 800 662-7801.

Q.3 : How do I repair Thermat in case of a malfunction?

A.3 : First, as a PREVENTIVE measure during installation, test the cable each time as specified in the installation guide. Also complete the measures' table.

However, in case of a malfunction, an authorized Ouellet Canada Inc. repair person will visit to LOCATE the fault and REPAIR it. It is recommended that you keep spare ceramic tiles or flooring for this purpose.

Q.4 : Are there other watt densities per square foot available?

A.4 : No. Ouellet Canada Inc. believes that 12W/sq. ft. is the best watt density to optimize comfort and prevent floor overheating. Moreover, the 240V and 120V systems provide equal heating power per square foot.

Q.5 : Can I crisscross, overlap, or touch two heating cables together?

A.5 : NEVER. This will cause overheating. Keep cables at least 76 mm (3") apart.

Q.6 : Can the cable be bent 90°?

A.6 : Yes, but make sure the radius bending is at least 20 mm (3/4"). Any bending smaller than this may damage the cable.

6.2 Installation

Q.7 : Can I install one Thermat system on top of another?

A.7 : NEVER. The system will overheat. Heating power must not exceed 12W/sq. ft (130W/m²).

Q.8 : Can Thermat be used for exterior snow melting?

A.8 : No. Thermat is designed to provide comfort and heating in indoor residential applications only.

Q.9 : Is a GFCI necessary?

A.9 : A GFCI is required in the bathroom. It is recommended for all other rooms.

Q.10 : Is a floor sensor necessary?

A.10 : Yes, to control floor surface temperature so that it does not exceed the floor covering's maximum temperature tolerance.

Even if it is not an obligation to use a floor sensor when using the system with an ambient thermostat, Ouellet Canada Inc. recommends the use of a floor sensor.

Q.11 : Can I connect two Thermat systems to the same thermostat?

A.11 : Yes. You can even connect additional systems provided the connection is parallel and total output does not exceed the thermostat's capacities.

Q.12 : What happens if the voltage applied is the wrong one?

A.12 : Connecting a 120V product to a 240V/208V current will overheat the system and lead to an overheating and failure. A 240V/208V product connected to a 120V current will produce virtually no heat. It is therefore very important to connect the right product to the right voltage.

Q.13 : Can Thermat be installed over concrete?

A.13 : Yes. Apply a concrete sealer before installing the **Thermat** system.
See Section 4.

Q.14 : Can carpet be installed over Thermat?

A.14 : Yes, if the system is completely embedded in self-levelling cement. You can install low-pile carpet over the slab if the carpet's thermal resistance does not exceed $R = 1.40$ ($RSI = 0.246$).

Q.15 : Can wood flooring be installed over Thermat?

A.15 : Yes, you can install multilayer wood flooring (Engineered flooring), provided its thermal resistance does not exceed $R = 1.40$ ($RSI = 0.246$).

Q.16 : Is the use of self-levelling cement mandatory when installing ceramic tile?

A.16 : If the room is small, an experienced tiler can do a good job without using self-levelling cement, but this method is not recommended. The heating cable must always be completely embedded in cement or an equivalent binder (cement glue, ceramic glue, self-levelling cement). If the room is medium-sized or large, the use of self-levelling cement is strongly recommended to ensure the ceramic is perfectly levelled.

7.1 Installation Tips

- For multilayer wood flooring (engineered floor) or linoleum, it is recommended that you consult the manufacturer to verify whether these floor coverings are compatible with a floor heating system;
- Keep the strips of fiberglass mesh cut during installation and, as necessary, place them over the heating cable if you have detached it from the mat and laid it out by hand (fig. 7.1);
- Though unlikely, the floor temperature sensor may need to be replaced. Ouellet Canada Inc. recommends installing a flexible plastic tube from the sensor to the thermostat on the wall;
- Fasten the cold lead and floor sensor to a concrete subfloor with adhesive (hot glue, tape, recycled **Thermat** mesh section).

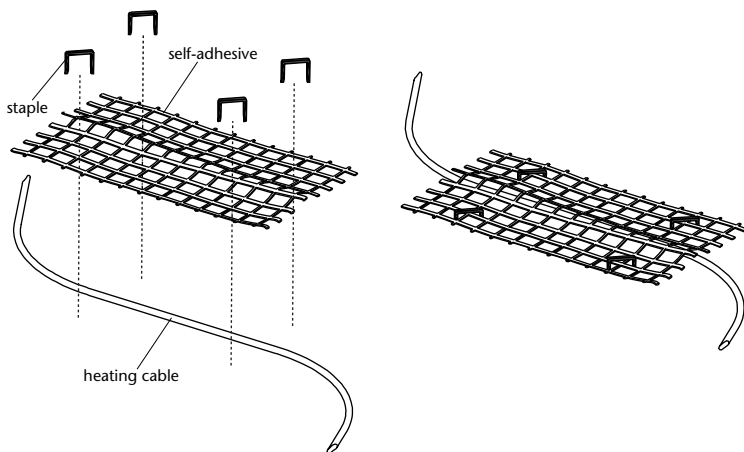

Fig. 7.1

7.2 Floor Covering Tips

- It is strongly recommended to coat the subfloor with a sealer before spreading the self-levelling cement (which is very liquid). This is to prevent any leaks under the floor;
- The use of a latex primer on a concrete subfloor is recommended to ensure the self-levelling cement adheres better to the concrete;
- With multilayer wood flooring (engineered floor), applying a minimum 5 mm (3/16") layer of self-levelling cement on the heating cable is recommended. To completely embed the cable in the cement or cement glue;
- To increase mat stability when unrolled, you may apply a second layer of spray adhesive to the concrete surface;
- It is important to respect the drying times recommended by the manufacturer to prevent residual moisture from affecting the adherence of floor coverings such as vinyl, linoleum, or wood.

8.1 Warranty Statement

Subject to the legal warranties relating to quality and durability of goods provided for by the Consumer Protection Act:

Ouellet Canada Inc. warrants the **Thermat** heating cables (OTM series) of its floor heating system for a 25-year period beginning from the date of purchase, against any malfunction or manufacturing defect.

Limitations and exclusions

The above mentioned warranties are restricted to the reimbursement of the original purchase cost and replacement of the heating cables and/or defective thermostat (hereinafter the “equipments”) excluding any other part also excluding any cost or any expense relating to the connection, removal, installation or fixing of the aforesaid equipments, including workmanship costs.

Ouellet Canada Inc. leaves the purchaser the care to choose between reimbursement of the purchase cost or replacement of the defective equipments, subject to the abovementioned restrictions.

The present warranties are granted to the original purchaser of the equipments as well as to the subsequent buyer of the building where it has been installed.

Terms of warranty

The present warranties are subject to the compliance of the following terms:

- i. Purchaser must provide **Ouellet Canada Inc.** or an authorized distributor or reseller with the original invoice for the defective equipments;
- ii. Purchaser must notify **Ouellet Canada Inc.**, in writing, of any defectiveness with the equipments aimed by the present warranties, in a reasonable time frame from the occurrence or knowledge of the defectiveness and give permission to **Ouellet Canada Inc.**'s representatives, the case being, to inspect the defective equipments;
- iii. The equipments aimed by the present warranties must have been installed in compliance with **Ouellet Canada Inc.**'s installation guidelines;
- iv. The equipments aimed by the present warranties must have been used in normal conditions and must have been kept under normal maintenance from the purchase date.

Name and address of the person granting the present warranty:

Ouellet Canada Inc.

180, 3^e Avenue

L'Islet (Québec) G0R 2C0 CANADA

Telephone: 1 800 463-7043 ou 418 247-3947

Fax: 1 800 662-7801 ou 418 247-7801

info@ouellet.com

www.ouellet.com