

OTM series

THERMAT Floor Heating System

The comfort of invisible heating

The **Thermat** floor heating system provides comfort and well-being through radiant heating. By heating the floor itself instead of the surrounding air, the system provides indirect heat that radiates from the floor up and is absorbed by surrounding objects, warming the entire room. As an integrated heating system, **Thermat** produces enveloping heat that is also clean, cost-effective, uniform, and constant.

Whether it is used for additional comfort or as a primary heat source, **Thermat** is a safe and "green" heating solution that harnesses the benefits of radiant heating, a process that occurs naturally in nature and has long been under-utilized in the industry.

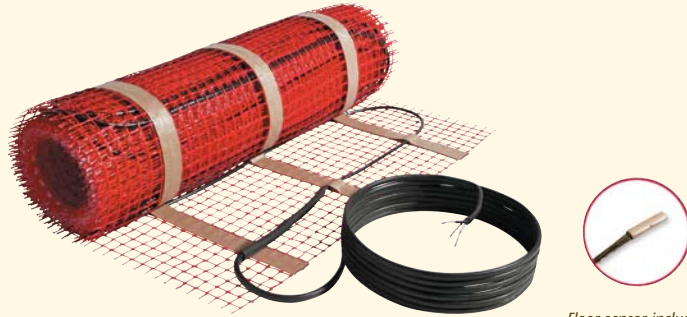

Floor sensor included



*Floor warming for ceramic floor in kitchen, bathroom including shower floor, hallway, and even staircases.
Radiant floor heating as a room's primary heat source in kitchen, bathroom and hallway.*



Features

- Voltage** - 120V, 240V/208V, 1-phase.
- Construction** - Heating cable made of a twin conductor for better mechanical resistance and negligible magnetic field in a protective PVC sheath fastened to an adhesive fiberglass mat with a cold lead of 13' 6" (4.2 m).
- Watt density** - 12W/sq. ft. (130W/sq. m).
- Dimension** - Mats of 16 in. (0.41 m) of width offered in several lengths.
- Cold lead length** - 13' 6" (4.2 m).
- Control** - Non programmable electronic thermostat with backlight OTH700 and GFCI (120V or 240V/208V) sold separately.
- Programmable electronic thermostat with backlight TH115 and GFCI (120V or 240V/208V) sold separately.
- Installation** - **Never cut or shorten the heating cable.**
- For indoor residential applications only.
- On concrete slab or plywood subfloor.
- Warranty** - 25-year warranty on heating wire.
- 1-year warranty on thermostat.

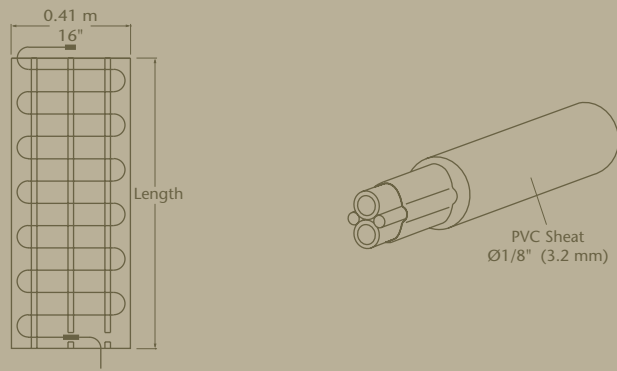

THERMAT Floor Heating System

Product #		Width		Length		Surface Area		Watts
240V/208V	120V	in.	mm	ft.	m	sq. ft.	sq. m	
----	OTM0082	16	0.41	6'	1.8	8	0.7	85
----	OTM0122	16	0.41	7' 9"	2.4	10	0.9	120
----	OTM0152	16	0.41	9' 9"	3.0	13	1.2	150
OTM0170	OTM0172	16	0.41	11' 3"	3.4	15	1.4	170
OTM0240	OTM0242	16	0.41	15' 3"	4.6	20	1.9	240
OTM0300	OTM0302	16	0.41	18' 9"	5.7	25	2.3	300
OTM0360	OTM0362	16	0.41	22' 6"	6.9	30	2.8	360
OTM0420	OTM0422	16	0.41	26' 6"	8.1	35	3.3	420
OTM0475	OTM0472	16	0.41	30'	9.1	40	3.7	475
OTM0600	OTM0602	16	0.41	37' 6"	11.4	50	4.6	600
OTM0720	OTM0722	16	0.41	45'	13.7	60	5.6	720
OTM0840	OTM0842	16	0.41	52' 9"	16.1	70	6.5	840
OTM0960	OTM0962	16	0.41	60'	18.3	80	7.4	960
OTM1080	----	16	0.41	67' 9"	20.7	90	8.4	1080
OTM1200	----	16	0.41	75' 3"	23.0	100	9.3	1200
OTM1440	----	16	0.41	90'	27.4	120	11.1	1440

208V = 75% of wattage at 240V.
15' floor sensor. 13' 6" cold lead.

Option

Product #	Description
LTC6832	Loctite - Spray adhesive to secure the mat on concrete slab.

Installation Steps

- Material required.
- Clean the subfloor well to ensure the mat adheres.
- Mark the work site.
- Make a channel to accommodate the cold lead.
- Change mat direction without cutting heating cable.
- Continue unrolling mat.
- Cover tight spaces and fit mat around obstacles.
- Test the integrity of the cable.
- Install floor temperature sensor.
- Spread-leveling cement. Then let dry. Floor covering may now be installed.
- Test the integrity of the cable.
- Turn on the Thermat Floor Heating System.

Backlight thermostats

The OTH700 Series electronic thermostats are specifically designed to regulate **Thermat** floor heating systems.

They feature a sensor to regulate and maintain floor or room temperature to within ± 1 °F of the setpoint. Designed for maximum safety, they include a ground-fault circuit interrupter (GFCI), which Ouellet strongly recommends for all rooms with heated floors.

To facilitate temperature control, the digital display indicates floor temperature at all times. A single touch activates the backlight display and indicates setpoint.

OTH700 series

Non Programmable Floor Heating Electronic Thermostat



Floor sensor included



Features

- Type** - Floor heating thermostat with LED backlight.
- Color** - White.
- Voltage** - 120V or 240V, battery-free setpoint temperature recorded permanently.
- Control** - Setpoint temperature precision within ± 1 °F.
- Temperature monitoring takes place 240 times per hour.
- T° range** - 40 °F to 104 °F.
- Vacation setpoint: 50 °F.

- Display** - Digital display of floor temperature (°C or °F) heating level indicator. Ground fault circuit interrupter included for safety with GFCI test light.
- On/standby switch to enable thermostat shutdown.
- Installation** - 4-wire thermostat.
- Warranty** - 1-year warranty against defects.

Models

Product #	Description	mA	Volts	Protection
OTH702-GA**	Non programmable electronic floor temperature control	5	120	GFCI*
OTH700-GA**		5	240/208	GFCI*
OTH702-GB**		15	120	GFCI*
OTH700-GB**		15	240/208	GFCI*

* GFCI: Ground fault circuit interrupter.

** 15' floor sensor.

TH115

Programmable Floor Heating Electronic Thermostat



Models

Product #	Description	Volts	mA	Protection
TH115-F-120-GA**	Programmable electronic floor temperature control	120	5	GFCI*
TH115-F-240-GA**		240/208	5	GFCI*
TH115-F-120-GB**		120	15	GFCI*
TH115-F-240-GB**		240/208	15	GFCI*

* GFCI: Ground fault circuit interrupter.

** 15' floor sensor.